

Property Record Card

Eagle County

**DE LA GARZA,
BERNARDO**

46 SUN KING DR
GLENWOOD SPRINGS, CO 81601-
9520

Account: R013477

Tax Area: SC103 - VAIL (TOWN) -
SC103

Acres: 0.206

Parcel: 2103-114-20-009

Situs Address:
002065 W GORE CREEK DR #9
VAIL AREA, 0

Value Summary

Value By:	Market	Override
Condo (1)	\$934,590	N/A
Land (1)	\$0	N/A
Extra Feature (1)	\$2,430	N/A
Extra Feature (2)	\$490	N/A
Extra Feature (3)	\$1,650	N/A
Extra Feature (4)	\$1,460	N/A
Total	\$940,620	\$940,620

Legal Description

Subdivision: CASA DEL SOL TOWNHOMES Unit: 9



Sale Data

Doc. #	Sale Date	Deed Type	Validity	Verified	Sale Price	Ratio	Adj. Price	Ratio	Time Adj. Price	Ratio
201202887	02/10/2012	WD	UI	Y	\$725,000	129.74	\$725,000	129.74	\$707,600	132.93
785803	01/28/2002	WD	UI	Y	\$180,000	522.57	\$180,000	522.57	\$388,260	242.27
R722817	11/17/1999	WD	QV	Y	\$360,000	261.28	\$360,000	261.28	\$2,880	32660.42

Condo Occurrence 1

Abstract Code	1230 - CONDOS-IMPROVEMENTS	Percentage	100
Use Code	1000 - RESIDENTIAL	Neighborhood	4461 - CASA DEL SOL
Building Type	123000 - CONDOMINIUM	Arch Style	26 - CONDO
Exterior Wall	31 - STONE VEN 16 - FRM STUCCO	Percentage	40 60

Property Record Card

Eagle County

Condo Occurrence 1

Roof Cover	6 - ASP SHGL	Roof Structure	2 - SHED
Interior Wall	5 - DRYWALL	Percentage	100.0
Floor	8 - RESILIENT 14 - CARPET INV	Percentage	20.0 80.0
Heating Fuel	3 - GAS	Heating Type	13 - BASEBOARD
Air Conditioning	0 - NONE	Actual Year Built	1980
Bedrooms	4	Bathrooms	3
Construction Quality	5 - GOOD	Effective Year Built	1995
Fixtures	11	Rooms	8
Units	1	Units	1
Super Neighborhood	4260 - WEST VAIL / INERMTN CONDO	Stories	3 - STORIES 3
Use Code	1000 - RESIDENTIAL	Garage	1 - GARAGE 001-350

SubArea	ACTUAL	EFFECTIVE	HEATED	FOOTPRINT
WDD	284.2			
GAF	243.6			243.6
LFT	261.9	209.5	261.9	261.9
BAS	994.5	994.5	994.5	994.5
ONE	984.5	984.5	984.5	984.5
Total	2,768.70	2,188.50	2,240.90	2,484.50
	Value	Rate	Rate	Rate
	\$934,590	337.56	427.05	417.06

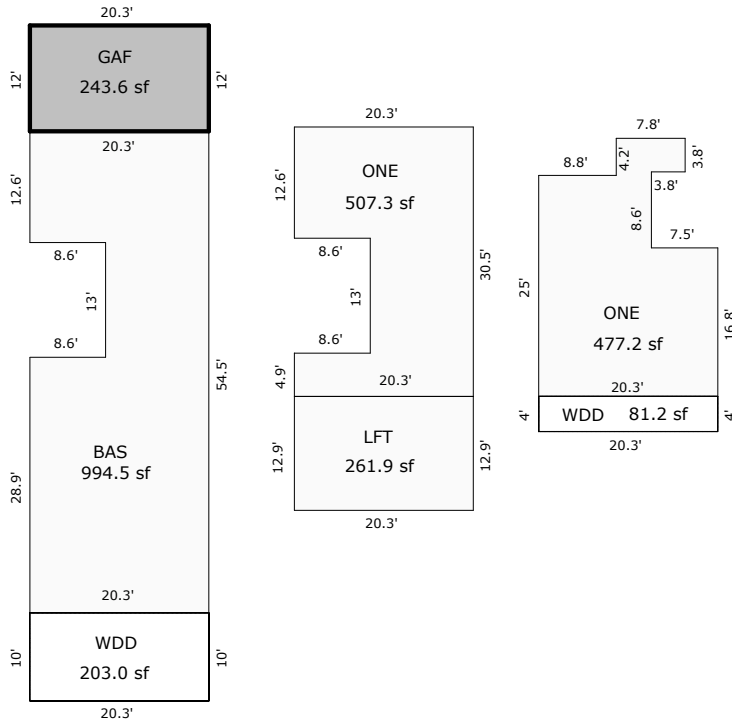

Sketch by Apex Medina™

Land Occurrence 1

Abstract Code	1130 - CONDO-LAND	Percentage	100.0
Use Code	1000 - RESIDENTIAL	Neighborhood	4461 - CASA DEL SOL
Land Code	11307776 - CASA DEL SOL	Super Neighborhood	4260 - WEST VAIL / INTERMTN CONDO

Property Record Card

Eagle County

Land Occurrence 1

Size	0.206	Zoning	6 - CONDO		
SubArea		ACTUAL	EFFECTIVE	HEATED	FOOTPRINT
Land A		0.206			
Total		0.206			
	Value	Rate	Rate	Rate	Rate
	\$0				

Extra Feature Occurrence 1

XFOB Code	110 - FIREPL. A.	Abstract Code	1230 - CONDOS-IMPROVEMENTS		
Percentage	100.0	Use Code	1000 - RESIDENTIAL		
Neighborhood	4461 - CASA DEL SOL	Building Number	0		
SubArea		ACTUAL	EFFECTIVE	HEATED	FOOTPRINT
XFOB Units		1			
Total		1.00			
	Value	Rate	Rate	Rate	Rate
	\$2,430	2,430.00			

Extra Feature Occurrence 2

XFOB Code	600 - INTERCOM A	Abstract Code	1230 - CONDOS-IMPROVEMENTS		
Percentage	100.0	Use Code	1000 - RESIDENTIAL		
Neighborhood	4461 - CASA DEL SOL	Building Number	0		
SubArea		ACTUAL	EFFECTIVE	HEATED	FOOTPRINT
XFOB Units		1			
Total		1.00			
	Value	Rate	Rate	Rate	Rate
	\$490	490.00			

Extra Feature Occurrence 3

XFOB Code	330 - HYDR-TUB A	Abstract Code	1230 - CONDOS-IMPROVEMENTS		
Percentage	100.0	Use Code	1000 - RESIDENTIAL		
Neighborhood	4461 - CASA DEL SOL	Building Number	0		
SubArea		ACTUAL	EFFECTIVE	HEATED	FOOTPRINT
XFOB Units		1			
Total		1.00			
	Value	Rate	Rate	Rate	Rate
	\$1,650	1,650.00			

Extra Feature Occurrence 4

XFOB Code	400 - STEAM SH A	Abstract Code	1230 - CONDOS-IMPROVEMENTS		
Percentage	100.0	Use Code	1000 - RESIDENTIAL		
Neighborhood	4461 - CASA DEL SOL	Building Number	0		
SubArea		ACTUAL	EFFECTIVE	HEATED	FOOTPRINT
XFOB Units		1			
Total		1.00			
	Value	Rate	Rate	Rate	Rate

Property Record Card

Eagle County

Extra Feature Occurrence 4

\$1,460

1,460.00

Abstract Summary

Code	Classification	Actual Value	Taxable Value	Actual Override	Taxable Override
1130	CONDO-LAND	\$0	\$0	NA	NA
1230	CONDOS-IMPROVEMENTS	\$940,620	\$67,720	NA	NA
Total		\$940,620	\$67,720	NA	NA